



Cam-Line[®]

Plastic Lined Trunnion Ball Valve



ITT

Contents

	Page
Introduction.....	3
Features	4
Lining Material, Seats, Testing	5
Cutaway Illustration	6
Technical Data	
Pressure / Temperature Curves.....	7
Operating Torques	7
Flow Coefficients (Cv Values).....	7
PVDF Coatings	7
Cam-Line® Options.....	8
Actuated Valves	9
Materials of Construction	10
Dimensions	
Manual Valves	10
Actuator Mounting.....	11
Service Guide	12–17
Ordering Information	18
Terms and Conditions of Sale	19

Introduction

ITT Industries, Engineered Valves Group (EVG) has been an innovator and producer of valves for over fifty years. These valves have gained extensive usage in many industries including power generation, pulp and paper, refineries, chemical process, pharmaceutical/bioprocessing and pollution control. As a recognized leader in the valve business, our heritage stems from diaphragm valves.

Through the years, our product offering has grown extensively. Our corrosion handling expertise has provided the impetus for the design of quarter-turn valve products like our Cam-Line® Ball Valve.

By developing products such as the Cam-Line that address specific problems encountered in industry, we continue to expand our commitment to remain a leader in flow control.

The performance of our products is surpassed only by the care taken in the many facets of manufacturing. Excellence in quality assurance, product reliability, and product safety will always remain paramount.



New Generation of Plastic Lined Valve

The Cam-Line trunnion ball valve was designed to overcome problems inherent in conventional lined plug and ball valves. The design objective was to produce a lined quarter-turn valve with positive shut off at high and low pressures, a valve with a stem seal that seals, and a valve that is convenient and safe to operate.

Design innovation has resulted in the valve we proudly call the Cam-Line. The Cam-Line ball valve combines the proven, patented sealing technology of the Cam-Tite ball valve with a trunnion mounting. The result is tight shut off, reliable stem seal performance, and a dramatic torque reduction never before possible in a plastic lined quarter-turn valve.

The sealing mechanism begins as a sphere with a trunnion running through its vertical center. A waterway (port) passes through the center of the sphere. Around the edge of the waterway the spherical surface is cut away, forming a bevel that passes completely around the edge of the water-way. This is a very important feature of the design since it is the difference in the effective distance across the beveled surfaces and the distance across the spherical surface that actually energizes the seat when the valve is closed.

When the valve is open the seats rest against the beveled surfaces. Sealing takes place during closure of the valve when the spherical surface of the ball engages the seats.

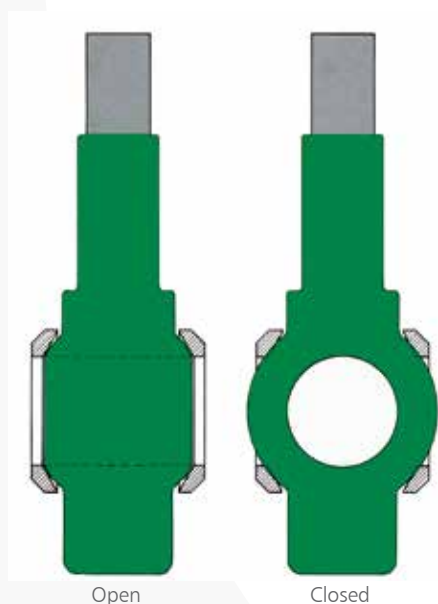

And, to make it easy for you to use, the Cam Line® ball valve features ANSI 150# flanges with standard laying lengths and flange pad mounting.

Sealing is the result of designed seat compression, not the result of pressure or of crushing components together. The resultant seal is positive at both high and low pressures. And, since load on the seats is minimized when the valve is in the open position, cold flow of the seat material is dramatically reduced, prolonging seat life. With the sealing load on the seats controlled by the geometry of the components (not external adjustments as in lined plug valves), the Cam-Line is a safe and convenient valve to operate. A 6" Cam-Line requires less than 1,250 inch pounds to operate. No gears or cheaters required here!

An important consideration when using plastics in valves is the dimensional stability of the plastic elements. Reliable performance is dependent upon maintaining design dimensions. The objective is to get two or more components to meet each other so that nothing can get by them. Dimensional stability of the lining in the seal area is thus of prime importance. Conventional plug and ball valves place high loads on the plastic linings to get a seal, but often at the expense of valve life and operating ease.

To maximize valve life, the Cam-Line ball valve uses a trunnion not only to support and center the ball, but also as a method to distribute excess hydraulic load into the valve body in non-critical areas, rather than through the seating area. Result? The Cam-Line performs better and longer, even in thermal cycling applications.

The trunnion also aids the stem seal at the top of the valve. The long trunnion shaft reduces the effects of lateral loading found in conventional ball valves and when coupled with the low operating torques, produces a seal that proves a lined valve can have a good stem seal.

Design innovation didn't stop with the basic valve. The choice of plastics and plastic processes has a direct effect on performance. So we engineered those, too. Our unique glass reinforced RTFE seats, along with a high stability ETFE thermoplastic lining, complete the package.

The Cam-Line® is an innovative design that gives:

- Positive Shut Off**
- Reliable Stem Sealing**
- Low Operating Torque**
- Convenient and Safe Operation**
- Long Service Life**

Material Processing for Better Results

All PTFE Seats are Not Created Equal

All Cam-Line seats are reinforced PTFE. The finished reinforced seats, when compared to virgin PTFE, exhibit the following performance advantages:

1. Improved dimensional stability
2. More uniform quality
3. Improved sealing characteristics

These properties, obtained through the reinforcing process, result in better sealing and longer seat life. Cam-Line reinforced PTFE seats, combined with the unique beveled edge ball design, result in superior shut-off performance.

Plastic Lining

All wetted parts of the Cam-Line are lined with plastic. Cam-Line linings are injection molded at high pressure. With injection molding we actually “build” a corrosion resistant plastic valve within the strong metal valve body. With injection molding, wall thickness can be varied to suit the mechanical requirements of the various valve sections, while minimum wall thickness is strictly controlled. In fact, all Cam-Line linings have a 3/16" minimum wall thickness. Cam-Line linings are “keyed” to the valve bore for extra stability. The one piece trunnion/ball of the Cam-Line is fully encapsulated with the plastic lining. The metal core is recessed and keyed to lock the lining in place. With the one-piece trunnion/ball design, the joint between the ball and stem as found in conventional lined ball valves is completely eliminated. You can be sure that the ball is in the position indicated by the top of the trunnion.

Experience Counts

Injection molding of plastic linings is not new to Engineered Valves Group (EVG). Initially introduced with its diaphragm valve product line, EVG has been molding plastic lined valves for the past fifty years. This experience and expertise led to the development of the patented “Boteler” method of injection molding valve linings in 1968. Over the years, thousands upon thousands of ball valves and diaphragm valves have been lined using this time proven method.



Testing

Every valve is tested prior to shipment. Both hydrostatic and seat tests (in accordance with MSS-SP-72) are performed to insure a high integrity, tight sealing valve. In addition, all plastic lined components are 100% spark tested prior to assembly to assure lining integrity.

ETFE Lining

ETFE can best be described as a rugged thermoplastic with an outstanding balance of properties. ETFE can perform successfully in applications where other materials are lacking in mechanical toughness, broad thermal capability, and the ability to meet severe environmental conditions.

Chemically, ETFE is a co-polymer of ethylene and tetrafluoroethylene. Mechanically, ETFE is tough, exhibits high tensile strength and hardness, and is more creep resistant than PTFE, FEP or PFA fluorocarbon resins. The ETFE used in the Cam-Line is reinforced with glass, yielding a tensile strength approaching 12,000 PSI. ETFE has outstanding resistance to attack by chemicals and solvents that often cause rapid deterioration of other plastic materials. ETFE is inert to strong mineral acids, inorganic bases, halogens, and metal salt solutions. Carboxylic acids, anhydrides, aromatic and aliphatic hydrocarbons, alcohols, aldehydes, ketones, ethers, chlorocarbons, and classic polymer solvents have little effect on the material.

Plastic Lined Trunnion Ball Valve

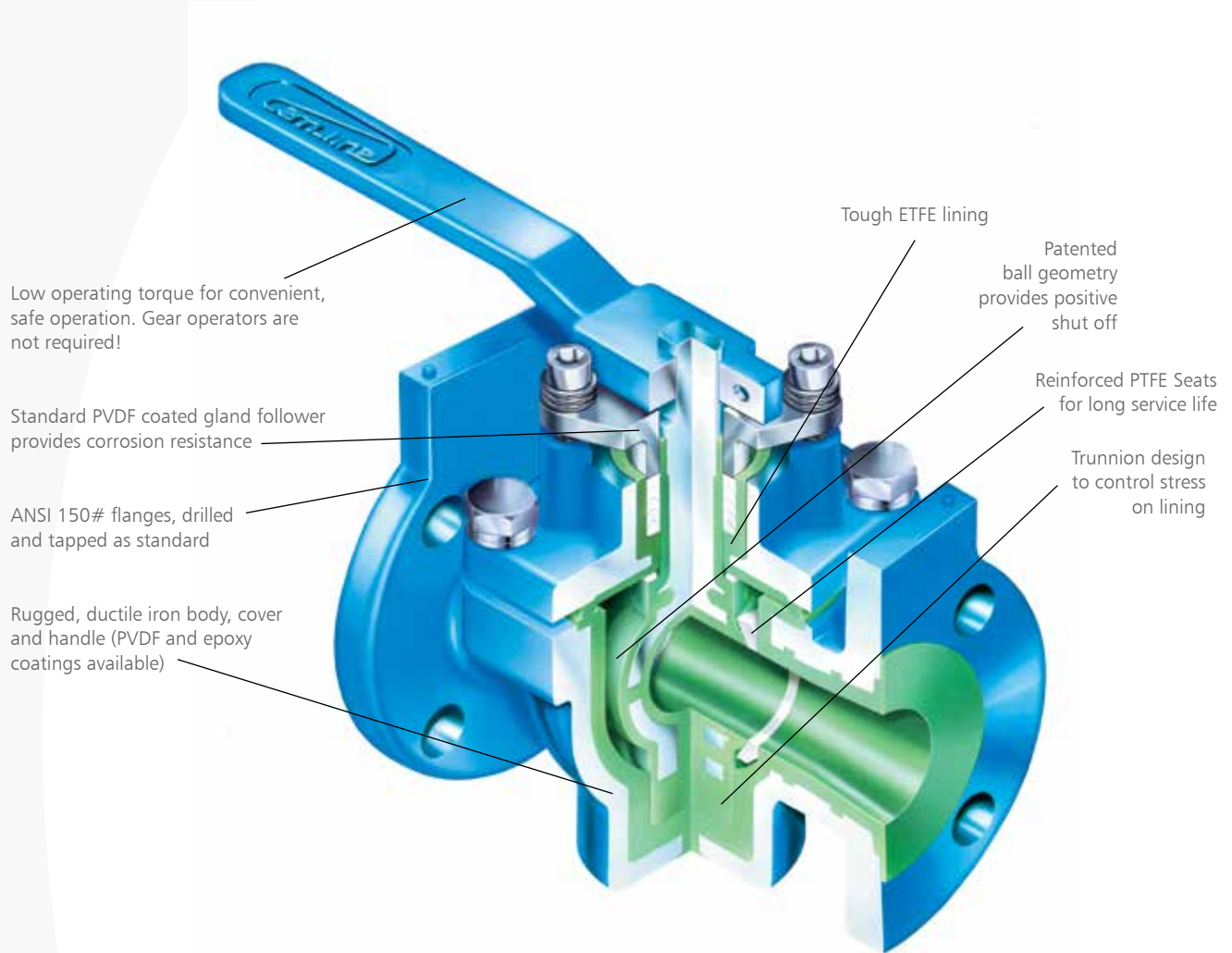

Live loaded multi-ring stem packing

From its inception the Cam-Line ball valve has utilized an emission reduction stem packing design. Multiple V-rings are placed in a deep stuffing box and are loaded via the gland follower using adjustable cap screws. Belleville spring washers are employed to maintain packing compression and to adjust for service variables.



Cam-Line® Technical Data

Operating Torques/Flow Coefficients (Cv)

The actual amount of torque required to operate a valve is dependent upon many variables, such as line pressure, temperature, type of fluid, frequency of operation, etc. The following tables are based on average breakaway torque requirements for a valve handling a clean, particle free liquid such as water. The torque values listed should be adjusted for special service conditions. For fluids with high solids or abrasive content, consult factory for recommendations.

When sizing an actuator for automatic operation, it is recommended not to exceed the Maximum Stem Torque as noted below. This will avoid permanent damage to the valve stem as a result of a blocked valve and an oversized operator.

Size	Torque (in lbs.)	Max. Stem Torque (in lbs.)
¾"-1"	120	709
1½"	130	1870
2"	280	1870
3"	500	3030
4"	800	5740
6"	1250	24500

Flow Coefficients (Cv)	
¾"-1"	30
1½"	73
2"	160
3"	355
4"	751
6"	800

Pressure/Temperature Curve for ETFE Lining Reinforced PTFE Seats

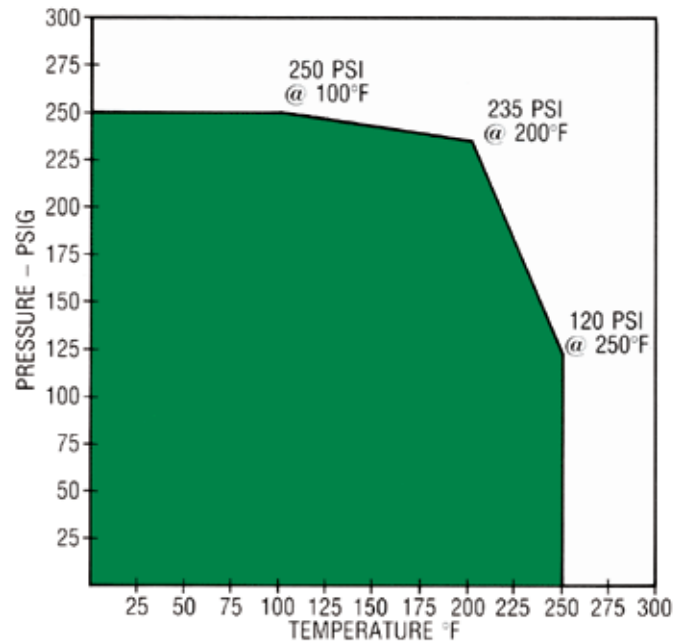

Cam-Line Options

External Protection with Corrosion Resistant PVDF

For ultimate exterior corrosion protection in aggressive chemical environments, Cam-Line ball valves can be externally coated with PVDF. A popular feature of the Dia-Flo® Diaphragm Valve, this optional 6-8 mil coating is applied to all ductile iron components of the Cam-Line prior to the valve being lined. The result is a mechanically tough coating that is resistant to spills, splash, and corrosive atmospheres at temperatures to 200°F. ETFE lined Cam-Line ball valves coated with PVDF are equipped with stainless steel fasteners to enhance total corrosion resistance.



Cam-Line® Options (continued)



Cavity Vents/Chlorine

When specified, Cam-Line ball valves can be provided with a vented seat to relieve excess pressure within the body cavity. Such valves are unidirectional and include an external tag with an arrow to indicate the direction of seat tightness. Use suffix "V" in the configuration number to specify a vented cavity only. Use "CLV" to specify a vented valve prepared for chlorine service. Note: As the Cam-Line is an ANSI 150# design, Engineered Valves Group (EVG) only recommends the valve for Class 1 dry chlorine gas service.

Grounding Devices

Upon request Cam-Line ball valves can be equipped with a grounding strap to provide electrical continuity between all metal components. Grounded valves receive a continuity test prior to shipment to assure a resistance reading less than 5 ohms. Use suffix "G" in the configuration number to specify a grounding device.

Oxygen Service

Cam-Line ball valves can be prepared for oxygen service. Oxygen preparation includes special cleaning, assembly, testing, and packaging. Valves prepared for oxygen service are lubricated with Krytox® 206 and are equipped as standard with a grounding strap. Use suffix "OX" in the configuration number to specify oxygen preparation.

Locking Devices

When required, Cam-Line ball valves can be supplied with a locking handle device to provide lockout in both the open and closed positions. These locking devices, designed to meet the requirements of OSHA 1910.147, can be supplied with new valves or can be retrofit to existing valves which have drilled and tapped flange pads. Stainless steel is the standard material of construction for the Cam-Line locking device. Use suffix "LDS" in the configuration number to specify this lockout feature.



Handle Options

The unique low torque design of the Cam-Line allows the use of lever handles throughout the entire size range. In addition to the standard lever handles, the following handle options can be supplied:

- Oval Safety Handwheels (through 2")
- 45° T Handles for chain operation (specify valve in vertical or horizontal position)
- Extended Handles (specify extension length)

For additional information on how to order the above options, see page 18 of the catalog. For additional technical information, contact your Engineered Valves Group (EVG) Technical Sales Representative.

Actuated Valves

With its simple, 90 degree rotation, the Cam-Line ball valve can be easily supplied with a variety of quarter-turn operators for automated valve service. Utilizing flange pads for actuator mounting, the low torque design of the Cam-Line allows smaller, less costly actuation devices to be employed.

Another advantage of actuating the Cam-Line comes from the camming action of the ball. Since there is virtually no load on the seats when the valve is in the open position, there is no high "breakaway torque" associated with beginning the closing cycle. The actuator is able to start motion from the open position with little resistance. Only when the valve is essentially closed does the actuator see the design torque of the valve. This operation is extremely beneficial for "fail closed" valves in hostile service conditions.

The Cam-Line ball valve can be equipped with a wide range of actuator types (pneumatic and electric) and can be packaged with an assortment of accessory components, such as solenoid valves and limit switches.

Compact Actuator

The Compact quarter-turn pneumatic actuator has been developed to be a simple, reliable, and efficient valve operator by utilizing a patented rack and pinion design. Four separate racks, each driven by its own piston, develop torque around the centrally located pinion. The four rack concept permits operating air pressure to be applied to four pistons simultaneously, increasing torque output and reducing piston diameter and overall actuator size, compared to single and double rack designs. Symmetrically spaced at 90 degree angles around the central pinion, the Compact's four racks also achieve a more uniform load distribution between the rack and pinion, greatly reducing gear wear at these contact points and curbing stress on the pinion and piston seals. The result is a high cycle actuator design.

Compact Spring Return or Double Acting Cam-Line Ball Valve

Valve Size	DN	Available Operating Air			
		Double Acting		Spring Return-Fail Closed	
		60 psi / 4 bar	80 psi / 5.5 bar	60 psi / 4 bar	80 psi / 5.5 bar
3/4"-1"	15-25	C20DA	C15DA	C25-2A2B	C25-2C
1 1/2"	40	C20DA	C15DA	C25-2A2B	C25-2C
2"	50	C25DA	C25DA	C35-2A2B	C30-2C
3"	80	C30DA	C25DA	C45-2A2B	C35-2C
4"	100	C35DA	C30DA	C60-2A2B	C45-2C
6"	150	C45DA	C35DA	C60-2A2B	C60-2C

Notes: 1. Actuator sizing based on 20% safety factor.

2. Use higher safety factor when handling gases, viscous liquids and crystallizing media - consult factory.



A look at the design of the Compact reveals several other important product advantages:

- Minimal air consumption
- Energy efficiency
- Fast response
- Compact, lightweight design

The table below shows the Compact actuator sizing for Cam-Line ball valves. This table is based on standard operating torques for a valve handling a clean, particle-free liquid such as water. For dirty fluids or media with high solids or abrasive contents, consult the factory for sizing recommendations.

Dimensions for Manual Valves, Materials of Construction

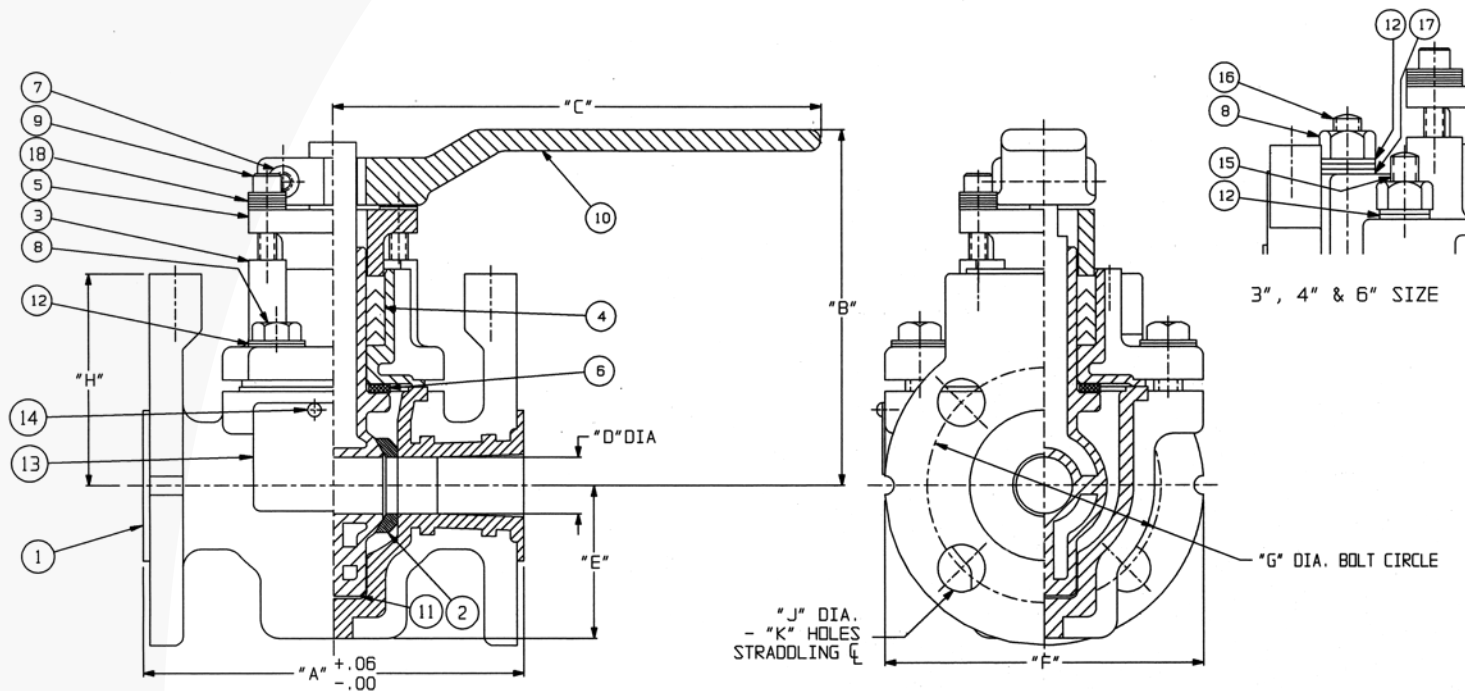

Inches

Valve Size	"A"	"B"	"C"	"D"	"E"	"F"	"G"	"H"	"J"	"K"	Weight-Lbs
3/4"	5.00	4.72	6.50	0.75	2.03	4.25	2.75	2.81	*		8.7
1"							3.12		0.62		9.5
1 1/2"	6.50	5.06	8.50	1.12	2.59	5.00	3.88	3.00	0.62	4	17.5
2"	7.00	5.38		1.50	3.03	6.00	4.75	3.12	0.75		24.0
3"	8.00	6.47	13.50	2.25	3.91	7.50	6.00	4.31	*0.75	8	49.5
4"	9.00	7.38		3.00	4.72	9.00	7.50	4.88	*0.75		71.0
6"	10.50	9.06		4.00	6.21	11.00	9.50	6.12	*0.88		148.0

MM

Valve Size	"A"	"B"	"C"	"D"	"E"	"F"	"G"	"H"	"J"	"K"	Weight-Kgs
3/4"							70.0		*		3.9
1"	127.0	119.9	165.1	19.1	51.6	108.0	79.2	71.4	15.7		4.3
1 1/2"	165.1	128.5	215.9	28.4	65.8	127.0	98.6	76.2	15.7	4	7.9
2"	177.8	136.7		38.1	77.0	152.4	120.7	79.2	19.1		10.8
3"	203.2	164.3	342.9	57.2	99.3	190.5	152.4	109.5	*19.1	8	22.3
4"	228.6	187.5		76.2	119.9	228.6	190.5	124.0	*19.1		32.0
6"	266.7	230.1		101.6	157.7	279.4	241.3	155.4	*22.4		66.6

* 3/4" 150 Lb. class flanged bolt holes are tapped 1/2"-13 UNC class 2B.
 Top two flanged bolt holes on 3" & 4" 150 Lb. class valves are drilled and tapped 5/8"-11 UNC class 2B.
 Top four flanged bolt holes on a 6" 150 Lb. class valve are drilled and tapped 3/4"-10 UNC class 2B.

Materials			
Item	Description	Material	Qty
1	Body (Lined)	DI ASTM A395 GR. 60-40-18	1
2	Seat	Reinforced PTFE	2
3	Cover (Lined)	DI ASTM A395 GR. 60-40-18	1
4	Packing, "V"-Ring (Complete Set)	PTFE	1
5	Follower, Gland-PVDF Coated	DI ASTM A536 GR. 65-45-12	1
6*	Washer, Thrust	PTFE	1
6**	O-Ring		
7	Screw, Hex Soc. Hd. Cap	CS	1
8	Screw, Hex Hd. Cap	CS ASTM A-193-B7	4
8+	Nut, Hvy. Hex	CS ASTM A-194-2H	4
8#			6
8##			10
9	Screw, Hex Soc. Hd. Cap	CS	2
10	Handle	DI ASTM A536 GR. 65-45-12	1
11	Ball/Stem (Lined)	DI ASTM A536 GR. 65-45-12	1
12	Washer, Belleville	SS	8
12#			12
12##			20
13	Plate, Identification	SS	1
14	Screw, Drive	CS	2
15	Stud	CS ASTM A-193-B7	4
15##			6
16#			2
16##	4		
17#	Flat Washer	SS	2
17##			4
18	Washer, Belleville	SS	12
	Lubricant	DuPont KRYTOX® GPL-206	

+3" only
*3/4" - 3"

#4 only
**4" and 6" only

##6" only

Dimensions for Actuator Mounting

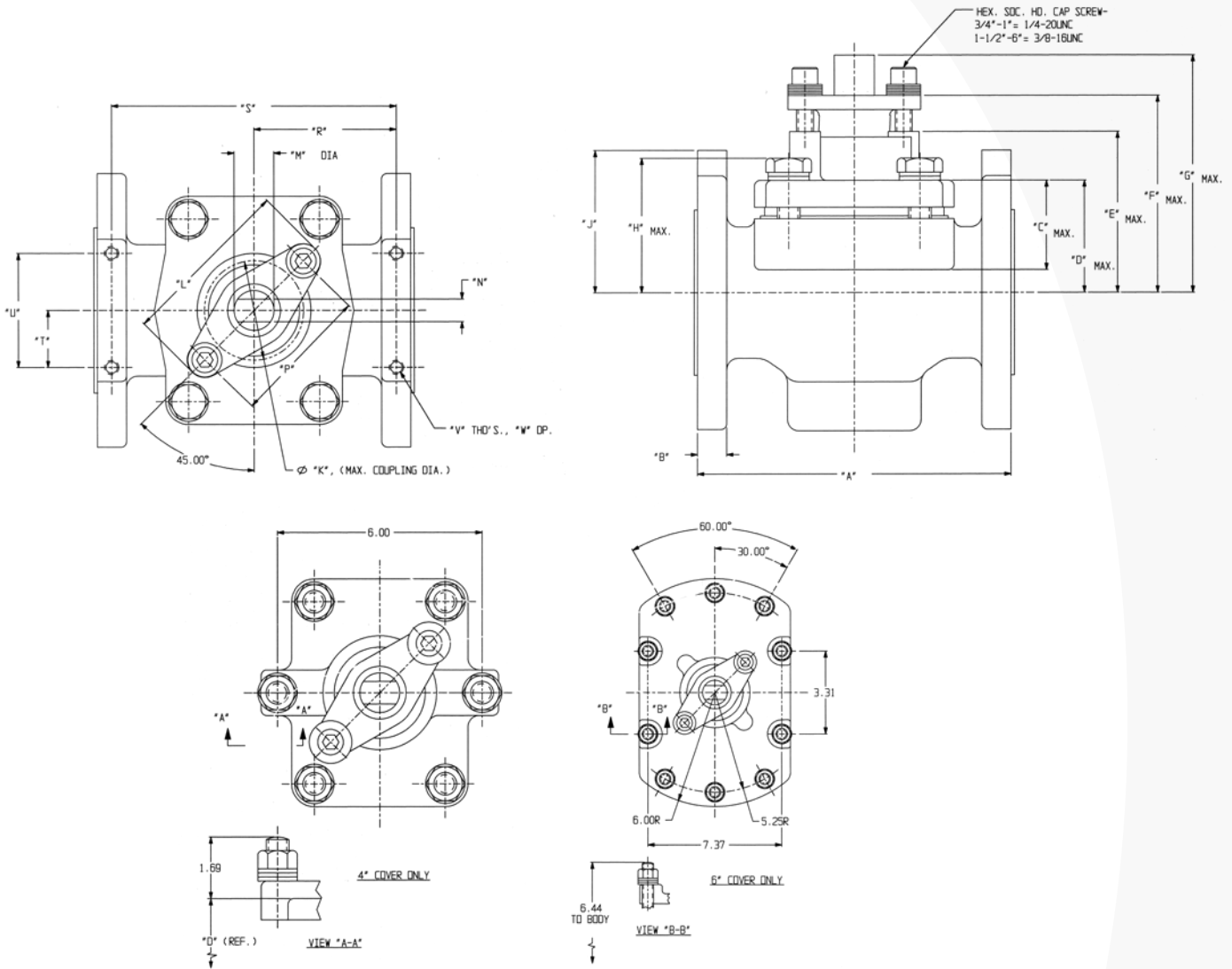

Inches

Valve Size	"A"	"B"	"C"	"D"	"E"	"F"	"G"	"H"	"J"	"K"	"L"	"M"	"N"	"P"	"R"	"S"	"T"	"U"	"V"	"W"
3/4" & 1"	4.88	.46	1.19	1.88	3.06	3.72	4.56	2.20	2.81	1.84	2.98	.62	.367/.363	2.469	2.10	4.19	.87	1.75	5/16-18UNC	.62
1 1/2"	6.38	.58	1.44	2.06	3.25	4.06	4.88	2.54	3.00	2.16	3.83	.88	.492/.488	3.062	2.81	5.62	.87	1.75	5/16-18UNC	.62
2"	6.88	.64	2.03	2.53	3.59	4.53	5.22	3.04	3.12	2.16	3.83	.88	.492/.488	3.062	3.10	6.19	1.12	2.25	5/16-18UNC	.62
3"	7.88	.78	1.94	3.12	4.31	5.25	6.16	4.06	4.31	2.81	5.07	1.00	.617/.613	4.062	3.56	7.12	1.75	3.50	3/8-16UNC	.75
4"	8.88	.97	2.19	3.62	5.09	5.97	7.09	4.38	4.88	2.69	5.07	1.25	.742/.738	4.062	4.00	8.00	2.00	4.00	7/16-14UNC	1.00
6"	10.38	1.03	2.41	5.03	6.44	7.69	8.82	5.88	6.12	3.81	6.19	2.00	1.242/1.238	5.188	4.66	9.31	2.56	5.12	7/16-14UNC	1.00

MM

Valve Size	"A"	"B"	"C"	"D"	"E"	"F"	"G"	"H"	"J"	"K"	"L"	"M"	"N"	"P"	"R"	"S"	"T"	"U"	"V"	"W"
3/4" & 1"	124.0	11.7	30.2	47.8	77.7	94.5	115.8	55.9	71.4	46.7	75.7	15.8	9.32/9.22	62.7	53.3	106.4	22.1	44.4	5/16-18UNC	15.8
1 1/2"	162.1	14.7	36.6	52.3	82.6	103.1	124.0	64.5	76.2	54.9	97.3	22.4	12.50/12.40	77.8	71.4	142.8	22.1	44.4	5/16-18UNC	15.8
2"	174.8	16.3	51.6	64.3	91.2	115.1	132.6	77.2	79.2	54.9	97.3	22.4	12.50/12.40	77.8	78.7	157.2	28.4	57.2	5/16-18UNC	15.8
3"	200.2	19.8	49.3	79.2	109.5	133.4	156.5	103.1	109.5	71.4	128.8	25.4	15.67/15.57	103.2	90.4	180.8	44.4	88.9	3/8-16UNC	19.0
4"	225.6	24.6	55.6	91.9	129.3	151.6	180.1	111.2	124.0	68.3	128.8	31.8	18.85/18.75	103.2	101.6	203.2	50.8	101.6	7/16-14UNC	25.4
6"	263.7	26.2	61.2	127.8	163.6	195.3	224.0	149.4	155.4	96.8	157.2	50.8	31.55/31.45	131.8	118.4	236.5	65.0	130.0	7/16-14UNC	25.4

Service Guide

For ultimate exterior corrosion protection in aggressive chemical environments, Cam-Line ball valves can be externally coated with PVDF. A popular feature of the Dia-Flo® Diaphragm Valve, this optional 6–8 mil coating is applied to all ductile iron components of the Cam-Line prior to the valve being lined. The result is a mechanically tough coating that is resistant to spills, splash, and corrosive atmospheres at temperatures to 200° F. ETFE lined Cam-Line ball valves coated with PVDF are equipped with stainless steel fasteners to enhance total corrosion resistance.

Data, recommendations, and suggestions contained herein are based on experiences in actual field applications as well as common corrosion data. However, because of so many possible variances in practices from plant to plant, these recommendations are intended for use only as a guide and should not be interpreted as a guarantee.

Selections in the following pages have been made with safety and serviceability as the foremost considerations.

Many variables enter into the question of serviceability. Factors such as concentration, temperature, pressure, velocity, percent solids, temperature cycling, vacuum, cleaning practices, etc. are all important in determining whether or not a particular material will give satisfactory service.

Of the endless number of chemical compounds many are insoluble in water and would consequently cause no corrosion problems when in water. However, some of these simple services can become difficult when it is necessary to make such materials soluble through use of some other solvent. For example, sulfuric acid is commonly used as a solvent for silver chloride. Then the recommendation must take into account both silver chloride and sulfuric acid. As a general rule, it is recommended that pipeline or tank material be used for the valve body whenever possible.

Engineered Valves cannot accept responsibility for the accuracy, currency or reliability of the information contained herein. Selection of materials is at the sole risk of the user. Consult factory for services not listed.

Chemical	Max Use Temp.	
	°F	°C
Acetaldehyde	200	95
Acetamide	250	120
Acetic Acid (50%)	250	120
Acetic Acid (Glacial)	230	110
Acetic Anhydride	250	120
Acetone	150	65
Acetone (50% H ₂ O)	150	65
Acetonitrile	150	65
Acetophenone	250	120
Acetylchloride	150	65
Acetylene	250	120
Acetylene Tetrabromide	250	120
Acetylene Tetrachloride	250	120
Acrylonitrile	150	65
Adipic Acid	250	120
Air	250	120
Allyl Alcohol	212	100
Allyl Chloride	212	100
Aluminum Ammonium Sulfate	250	120
Aluminum Chloride	250	120
Aluminum Fluoride	250	120
Aluminum Hydroxide	250	120
Aluminum Nitrate	250	120
Aluminum Oxychloride	250	120
Aluminum Potassium Sulfate	250	120
Amino Acids (H ₂ O)	212	100
Ammonia (Anhydrous)	250	120
Ammonia (Aqueous 30%)	230	110
Ammonium Bifluoride	250	120
Ammonium Bromide (50%)	250	120
Ammonium Carbonate	250	120
Ammonium Chloride	250	120
Ammonium Dichromate	250	120
Ammonium Dichromate	250	120
Ammonium Fluoride	250	120
Ammonium Hydroxide	250	120
Ammonium Nitrate (Conc.)	230	110

Chemical	Max Use Temp.	
	°F	°C
Ammonium Perchlorate	250	120
Ammonium Persulfate	150	65
Ammonium Phosphate	250	120
Ammonium Sulfate	250	120
Ammonium Sulfide	250	120
Ammonium Thiocyanate	250	120
Amyl Acetate	250	120
Amyl Alcohol	250	120
Amyl Chloride	250	120
Aniline	230	110
Aniline Hydrochloride (10%)	150	65
Anthraquinone	250	120
Anthraquinone-Sulfonic Acid	250	120
Antimony Trichloride	212	100
Aqua Regia	212	100
Arsenic Acid	250	120
Barium Carbonate	250	120
Barium Chloride	250	120
Barium Hydroxide	250	120
Barium Sulfate	250	120
Barium Sulfide	250	120
Battery Acid	250	120
Benzaldehyde	212	100
Benzene	212	100
Benzene Sulfonic Acid	212	100
Benzoic Acid	250	120
Benzoyl Chloride	150	65
Benzyl Alcohol	250	120
Barium Sulfate	250	120
Barium Sulfide	250	120
Battery Acid	250	120
Benzaldehyde	212	100
Benzene	212	100
Benzene Sulfonic Acid	212	100
Benzoic Acid	250	120
Benzoyl Chloride	150	65
Benzyl Alcohol	250	120

Chemical	Max Use Temp.	
	°F	°C
Benzyl Chloride	250	120
Bismuth Carbonate	250	120
Black Liquor	250	120
Bleach (12.5% CL ₂)	212	100
Borax	250	120
Boric Acid	250	120
Brine	250	120
Bromic Acid	250	120
Bromine (Dry)	150	65
Bromine Water (10%)	230	110
mono-Bromotoluene	212	100
Bromoform	212	100
m-Bromotoluene	212	100
Butadiene	250	120
Butane	250	120
Butanediol	250	120
Butyl Acetate	230	110
Butyl Acrylate	230	110
n-butyl Alcohol	250	120
sec-Butyl Alcohol	250	120
tert-Butyl Alcohol	250	120
n-Butylamine	120	50
sec-Butylamine	120	50
tert-Butylamine	120	50
di-n-Butylamine	230	110
tri-n-Butylamine	230	110
Butylene	250	120
Butyl Bomide	250	120
Butyl Chloride	250	120
n-Butyl Mercaptan	250	120
Butyl Phenol	230	110
Butyl Phthalate	150	65
Butyraldehyde	212	100
Butyric Acid	250	120
Calcium Bisulfate	250	120
Calcium Bisulfide	250	120
Calcium Carbonate	250	120
Calcium Chlorate	250	120
Calcium Chloride	250	120
Calcium Hydroxide	250	120
Calcium Hypochlorite	250	120
Calcium Nitrate	250	120
Calcium Oxide	250	120
Calcium Sulfate	250	120
Calcium Sulfide	250	120
Caprylic Acid	212	100
Carbon Dioxide (Dry)	250	120
Carbon Dioxide (Wet)	250	120
Carbon Disulfide	150	65
Carbon Monoxide	250	120
Carbon Tetrachloride	150	65
Carbonic Acid	250	120

Chemical	Max Use Temp.	
	°F	°C
Castor oil	250	120
Caustic Potash (10 and 50%)	212	100
Caustic Soda (10 and 50%)	212	100
Cellosolve®	250	120
Chloral Hydrate	212	100
Chlorinated Brine	250	120
Chlorinated Phenol	212	100
Chlorine (Dry)	212	100
Chlorine (Wet)	250	120
Chlorine Dioxide	250	120
Chloroacetic Acid (50% H ₂ O)	230	110
Chlorobenzene	212	100
Chlorobenzyl Chloride	150	65
Chloroform	212	100
Chlorohydrin (Liquid)	150	65
Chlorosulphonic Acid	75	25
Chromic Acid (50%)	150	65
Chromic Chloride	212	100
Chromyl Chloride	212	100
Clorox Bleach Solution (5-1/2% CL ₂)	212	100
Coal Gas	212	100
Copper Chloride	250	120
Copper Cyanide	250	120
Copper Fluoride	250	120
Copper Nitrate	250	120
Copper Sulfate	250	120
Cresol	250	120
Cresylic Acid	250	120
Croton Aldehyde	212	100
Crude Oil	250	120
Cyclohexane	250	120
Cyclohexanol	250	120
Cyclohexanone	250	120
DDT	212	100
Decalin	250	120
Decane	250	120
Dextrin	250	120
Deacetone Alcohol	212	100
1,2-Dibromopropane	200	95
Dibutyl Phthalate	150	65
Dichloroacetic Acid	150	65
o-Dichlorobenzene	150	65
Dichloroethylene	150	65
Dichloropropionic Acid	150	65
Diesel Fuels	250	120
Diethyl Benzene	250	120
Diethyl Cellosolve	250	120
Diethyl Ether	212	100
Diethylamine	230	110
Diglycolic Acid	212	100
Diisobutyl Ketone	230	110
Diisobutylene	250	120

Chemical	Max Use Temp.	
	°F	°C
Dimethyl Formamide	250	120
Dimethyl Phthalate	212	100
Dimethyl Sulfate	150	65
Dimethyl Sulfoxide	212	100
Dimethylamine	120	50
Dimethylaniline	250	120
Diocetyl Phthalate	150	65
p-Dioxane	150	65
Diphenyl Ether	175	80
Divinyl Benzene	175	80
Epichlorhydrin	150	65
Ethyl Acetate	150	65
Ethyl Acrylate	212	100
Ethyl Alcohol	250	120
Ethyl Chloride	250	120
Ethyl Chloroacetate	212	100
Ethyl Cyanoacetate	212	100
Ethylacetoacetate	150	65
Ethylamine	100	40
Ethylene Bromide	250	120
Ethylene Chloride	250	120
Ethylene Chlorohydrin	150	65
Ethylene Diamine	120	50
Ethylene Glycol	250	120
Ethylene Oxide	230	110
Fatty Acids	250	120
Ferric Chloride (50% H ₂ O)	250	120
Ferric Hydroxide	250	120
Ferric Nitrate	250	120
Ferric Sulfate	250	120
Ferrous Chloride	250	120
Ferrous Hydroxide	250	120
Ferrous Nitrate	250	120
Ferrous Sulfate	250	120
Fluorine (Gaseous)	100	40
Fluoroboric Acid	250	120
Fluosilicic Acid	250	120
Formaldehyde (37% in H ₂ O)	230	110
Formic Acid	250	120
FREON® 11	230	110
FREON® 12	230	110
FREON® 22	230	110
Fuel Oil	250	120
Fumaric Acid	200	95
Furane	150	65
Furfural	212	100
Gallic Acid	212	100
Gas-Manufactured	250	120
Gas-Natural	250	120
Gasoline-Leaded	250	120
Gasoline-Sour	250	120
Gasoline Unleaded	250	120

Chemical	Max Use Temp.	
	°F	°C
Glycerol	250	120
Glycol	250	120
Glycolic Acid	250	120
Heptane	250	120
Hexane	250	120
Hydrazine	100	40
Hydrazine Dihydrochloride	125	50
Hydriodic Acid	250	120
Hydrobromic Acid (50%)	250	120
Hydrochloric Acid (20%)	250	120
Hydrochloric Acid (Conc.)	250	120
Hydrochloric Acid (Gas)	250	120
Hydrocyanic Acid	250	120
Hydrofluorosilicic Acid	250	120
Hydrogen	250	120
Hydrogen Cyanide	250	120
Hydrogen Peroxide (30%)	250	120
Hydrogen Peroxide (90%)	150	65
Hydrogen Phosphide	150	65
Hydrogen Sulfide (Dry)	250	120
Hydrogen Sulfide (Wet)	250	120
Hydroquinone	250	120
Hypochlorous Acid	250	120
Inert Gases	250	120
Iodine (Dry)	230	110
Iodine (Wet)	230	110
Iodoform	230	110
Isobutyl Alcohol	250	120
Isopropylamine	120	50
Jet Fuel-JP4	230	110
Jet Fuel-JP5	230	110
Lactic Acid	250	120
Lard Oil	250	120
Lauric Acid	250	120
Lauryl Chloride	250	120
Lauryl Sulfate	250	120
Lead Acetate	250	120
Linoleic Acid	250	120
Linseed Oil	250	120
Lithium Bromide (Saturated)	250	120
Lithium Hydroxide	250	120
Lubricating Oil	250	120
Magnesium Carbonate	250	120
Magnesium Chloride	250	120
Magnesium Hydroxide	250	120
Magnesium Nitrate	250	120
Magnesium Sulfate	250	120
Maleic Acid	250	120
Maleic Anhydride	200	95

Chemical	Max Use Temp.	
	°F	°C
Malic Acid	250	120
Mercuric Chloride	250	120
Mercuric Cyanide	250	120
Mercuric Nitrate	250	120
Mercury	250	120
Methacrylic Acid	200	95
Methane	250	120
Methane Sulfonic Acid (50%)	230	110
Methyl Alcohol	250	120
n-Methylaniline	250	120
Methyl Benzoate	250	120
Methyl Bromide	250	120
Methyl Cellosolve®	250	120
Methyl Chloride	200	95
Methyl Chloroform	150	65
Methyl Chloromethyl Ether	175	80
Methyl Cyanoacetate	175	80
Methyl Ethyl Ketone	230	110
Methyl Isobutyl Ketone	230	110
Methyl Methacrylate	175	80
Methyl Salicylate	200	95
Methyl Sulfuric Acid	212	100
Methyl Trichlorosilane	200	95
Methylene Bromide	212	100
Methylene Chloride	212	100
Methylene Iodide	212	100
Mineral Oil	250	120
Monochlorobenzene	230	110
Monoethanolamine	150	65
Morpholine	150	65
Naphta	250	120
Naphthalene	250	120
Nickel Chloride	250	120
Nickel Nitrate	250	120
Nickel Sulfate	250	120
Nicotine	212	100
Nicotinic Acid	250	120
Nitric Acid (50%)	150	65
Nitric Acid (Conc. 70%)	75	25
Nitric Acid-Sulfuric Acid (50/50)	212	100
Nitrobenzene	250	120
Nitrogen Dioxide	212	100
Nitrogen Gas	250	120
Nitromethane	212	100
Nitrous Acid	212	100
Octane	250	120
Octene	250	120
Oleic Acid	250	120
Oleum	120	50
Oxalic Acid	230	110
Oxygen	250	120
Ozone (<1% in Air)	212	100

Chemical	Max Use Temp.	
	°F	°C
Palmitic Acid	250	120
Perchlorethylene	250	120
Perchloric Acid (10%)	230	110
Perchloric Acid (72%)	150	65
Petrolatum	250	120
Petroleum	250	120
Petroleum Ether	212	100
Phenol (10%)	230	110
Phenol (100%)	212	100
Phenolsulfonic Acid	212	100
Phenylhydrazine	212	100
Phenylhydrazine Hydrochloride	212	100
o-phenylphenol	212	100
Phosgene	212	100
Phosphoric Acid (30%)	250	120
Phosphoric Acid (85%)	250	120
Phosphorus Oxychloride	212	100
Phosphorus Pentachloride	212	100
Phosphorus Pentoxide	230	110
Phosphorus Trichloride	250	120
Phthalic Acid	212	100
Phthalic Anhydride	212	100
Picric Acid	125	50
Polyvinyl Acetate	250	120
Polyvinyl Alcohol	250	120
Potassium Aluminum Chloride	250	120
Potassium Aluminum Sulfate (50%)	250	120
Potassium Bicarbonate	250	120
Potassium Borate	250	120
Potassium Bromate	250	120
Potassium Bromide	250	120
Potassium Carbonate	250	120
Potassium Chlorate	250	120
Potassium Chloride	250	120
Potassium Chromate	250	120
Potassium Cyanide	250	120
Potassium Dichromate	250	120
Potassium Ferrocyanide	250	120
Potassium Fluoride	250	120
Potassium Hydroxide (50%)	212	100
Potassium Hypochlorite	250	120
Potassium Nitrate	250	120
Potassium Perborate	250	120
Potassium Perchlorate	212	100
Potassium Permanganate	250	120
Potassium Persulfate	150	65
Potassium Sulfate	250	120
Potassium Sulfide	250	120
Propane	250	120
Propionic Acid	212	100
Propyl Alcohol	250	120
Propylene Dibromide	212	100

Chemical	Max Use Temp.	
	°F	°C
Propylene Dichloride	212	100
Propylene glycol Methyl Ether	212	100
Propylene Oxide	150	65
Pyridine	150	65
Pyrogallol	150	65
Salicylaldehyde	212	100
Salicylic Acid	250	120
Salt Brine	250	120
Sea Water	250	120
Silicon Tetrachloride	250	120
Silver Chloride	250	120
Silver Cyanide	250	120
Silver Nitrate	250	120
Sodium Acetate	250	120
Sodium Benzene-Sulfonate	250	120
Sodium Benzoate	250	120
Sodium Bicarbonate	250	120
Sodium Bisulfate	250	120
Sodium Bisulfite	250	120
Sodium Borate	212	100
Sodium Bromide	250	120
Sodium Carbonate	250	120
Sodium Chlorate	250	120
Sodium Chloride	250	120
Sodium Chromate	250	120
Sodium Cyanide	250	120
Sodium Dichromate (Alkaline)	212	100
Sodium Ferricyanide	250	120
Sodium Ferrocyanide	250	120
Sodium Fluoride	250	120
Sodium Glutamate	250	120
Sodium Hydroxide (10%)	230	110
Sodium Hydroxide (50%)	230	110
Sodium Hypochlorite	250	120
Sodium Hyposulfite	250	120
Sodium Iodide	250	120
Sodium Lignosulfonate	250	120
Sodium Metasilicate	250	120
Sodium Nitrate	250	120
Sodium Nitrite	250	120
Sodium Perborate	212	100
Sodium Perchlorate	150	65
Sodium Peroxide	250	120
Sodium Persulfate	175	80
Sodium Phosphate	250	120
Sodium Silicate	250	120
Sodium Silicofluoride	250	120
Sodium Sulfate	250	120
Sodium Sulfide	250	120
Sodium Sulfite	250	120
Sodium Thiosulfate	250	120
Sorbic Acid	250	120

Chemical	Max Use Temp.	
	°F	°C
Sour Crude Oil	250	120
Stannic Chloride	250	120
Stannous Chloride	250	120
Stannous Fluoride	250	120
Stearic Acid	250	120
Stoddard's Solvent	250	120
Styrene Monomer	212	100
Succinic Acid	250	120
Sulfamic Acid	212	100
Sulfur (Molten)	250	120
Sulfur Dioxide	230	110
Sulfur Trioxide (Liquid)	75	25
Sulfuric Acid (60%)	250	120
Sulfuric Acid (Conc.)	250	120
Sulfuric Acid (Fuming-Oleum)	120	50
Sulfurous Acid	230	110
Tall Oil	250	120
Tannic Acid	250	120
Tartaric Acid	250	120
2,3,4,6-Tetrachlorophenol	212	100
Tetraethyl Lead	250	120
Tetrahydrofuran	212	100
Tetramethyl Ammonium		
Hydroxide (50%)	212	100
Thionyl Chloride	212	100
Tin Tetrachloride	230	110
Titanium Dioxide	250	120
Titanium Tetrachloride	212	100
Toluene	250	120
Tributyl Phosphate	150	65
Trichloroacetic Acid	212	100
Trichloroethylene	250	120
Trichloromethane	212	100
2,4,5-Trichlorophenol	212	100
Triethylamine	230	110
Trisodium Phosphate	250	120
Turpentine	250	120
UDMH-Hydrazine (50/50)	120	50
Urea (50% H2O)	250	120
Varsol	250	120
Vinyl Acetate	250	120
Vinyl Chloride (Monomer)	150	65
Water	250	120
Water Sewage	250	120
Wax	250	120
Xylene	250	120
Zinc Acetate	250	120
Zinc Chloride	250	120
Zinc Hydrosulfite (10%)	250	120
Zinc Nitrate	250	120
Zinc Sulfate	250	120
Zinc Sulfide	250	120

How to Order Cam-Line Valves

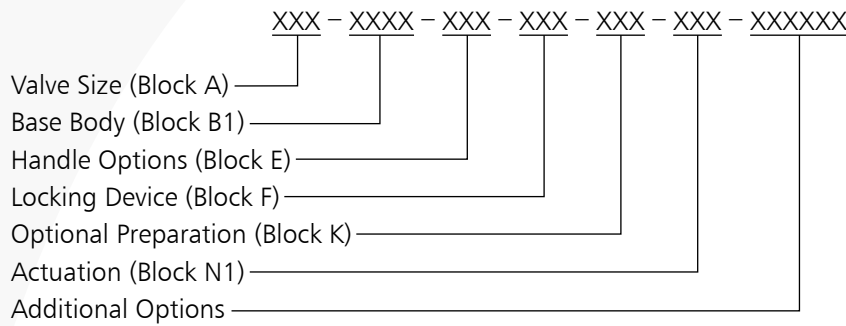

Figure Numbers:

Size Range

Cam-Line Ball Valves (Block A)

Code	Valve Size
0.75	3/4"
1	1"
1.5	1 1/2"
2	2"
3	3"
4	4"
6	6"

Flanged Ends - Lined

Cam-Line Ball Valves (Block B1)

Code	Lining Material
DUCTILE IRON - 150#	
1059	ETFE
1159	ETFE Lined (PVDF Coated)

Exterior Trim (Block D3)

Code	Material
ET1	Stainless Steel
ET2	Carbon Steel

Handle Options (Block E)

Code	Description
OVAL HANDWHEEL	
HD2	Carbon Steel
HD3	Stainless Steel
HD4	None Provided

CHAINWHEEL

HD5	Carbon Steel Horizontal Line
HD6	Carbon Steel Vertical Line
HD7	Stainless Steel Horizontal Line
HD8	Stainless Steel Vertical Line

Locking Device (Block F)

Code	Material
LDS	Stainless Steel

Grounding Strap (Block F1)

Code	Description
G	Grounding Strap

Optional Coatings (Block G)

Code	Coating
C1	White Epoxy
C2	Sherwin Williams Polane Blue
CSPEC	Customer Specified

Optional Preparation (Block K)

Code	Preparation
OX	Oxygen Preparation
CL	Halogen Service w/o Venting
CLV	Dry Chlorine Gas w/ Vented Seat
V	Vented Seat

Extended Stem (Block D2)

Code	Extension Length
EXTSP	Stem Extension w/o Bracket
EXTSPBR	Stem Extension w/ Bracket

Compact Actuator (Block N1)

Code	Actuator Model
C15	C15
C20	C20
C25	C25
C30	C30
C35	C35
C45	C45
C60	C60

Compact Actuator Mode (Block N2)

Code	Actuator Model
DA	Double Acting
SR	Spring Return
GR	Gear / Manual or Electric

Compact Actuator Springs (Block N3)

Code	Actuator Springs
2A	2A
2A2B	2A2B
2C	2C
3	3

Compact Actuator

Failure Position (Block N4)

Code	Failure Position
FO	Fail Open
FC	Fail Closed

Solenoid Valve (Block N5)

Code	Description
SV1	Asco 8320G184
SV2	Asco EF8320G184
SV3	Asco 8345G1
SV4	Asco EF8345G1
SV5	Asco EF8320G194
SV6	Asco EFHT8320G184
SVSPEC	Customer Specified

Actuator Limit

Switches (Block N7)

Code	Description
LS1N	WESTLOCK 1040NFC2A2M0200
LS2N	WESTLOCK 1040NBY2A2M0200
LS3N	WESTLOCK 2004NBY2A2M0200
LS4N	WESTLOCK 2007NBY2B2M0200
LS9N	WESTLOCK 2007NBY2E2M0200
LS10N	WESTLOCK 9479NBY2B2M0600
LS15N	WESTLOCK 9358NBY2A2M0600
LSSPEC	Customer Specified

Filter Regulator (Block N1R)

Code	Description
RF1	Fischer 67CFR
RF2	CONOFLOW FR95ASKEX1G
RFSPEC	Customer Specified

Speed Control (Block N1C)

Code	Description
SC	Schrader 337-1001

Conditions and Terms

CONDITIONS and TERMS of SALE of ITT ENGINEERED PROCESS SOLUTIONS GROUP (EPSG) (Hereinafter referred to as Seller)

- 1. CONTROLLING PROVISIONS:** These terms and conditions shall control with respect to any purchase order or sale of Seller's products. No waiver, alteration or modification of these terms and conditions whether on Buyer's purchase order or otherwise shall be valid unless the waiver, alteration or modification is specifically accepted in writing and signed by an authorized representative of Seller.
 - 2. DELIVERY:** Seller will make every effort to complete delivery of products as indicated on Seller's acceptance of an order, but Seller assumes no responsibility or liability, and will accept no back charge for loss or damage due to delay or inability to deliver caused by acts of God, war, labor difficulties, accident, delays of carriers, by contractors or suppliers, inability to obtain materials, shortages of fuel and energy or any other causes of any kind whatever beyond the control of Seller. Seller may terminate any contract of sale of its products without liability of any nature, by written notice to Buyer. In the event that the delay in delivery or performance resulting from any of the aforesaid causes shall continue for a period of sixty (60) days. Under no circumstances shall Seller be liable for any special or consequential damages or for loss, damage or expense (whether or not based on negligence) directly or indirectly arising from delays or failure to give notice of delay.
 - 3. WARRANTY:** Seller warrants for one year from the date of shipment Seller's manufactured products to the extent that Seller will replace those having defects in material or workmanship when used for the purpose and in the manner which Seller recommends. If Seller's examination shall disclose to its satisfaction that the products are defective, and an adjustment is required, the amount of such adjustment shall not exceed the net sales price of the defective products only and no allowance will be made for labor or expense of repairing or replacing defective products or workmanship or damage resulting from the same. Seller warrants the products which it sells of other manufactures to the extent of the warranties of their respective makers. Where engineering design or fabrication work is supplied, Buyer's acceptance of Seller's design or of delivery of work shall relieve Seller of all further obligation, other than as expressed in Seller's product warranty. THIS IS SELLER'S SOLE WARRANTY. SELLER MAKES NO OTHER WARRANTY OF ANY KIND, EXPRESSED OR IMPLIED, AND ALL IMPLIED WARRANTIES OF MERCHANTABILITY AND FITNESS FOR A PARTICULAR PURPOSE WHICH EXCEED SELLER'S AFORESTATED OBLIGATION ARE HEREBY DISCLAIMED BY SELLER AND EXCLUDED FROM THIS WARRANTY. Seller neither assumes, nor authorizes any person to assume for it, any other obligation in connection with the sale of its engineering designs or products. This warranty shall not apply to any products or parts of products which (a) have been repaired or altered outside of Seller's factory, in any manner; or (b) have been subjected to misuse, negligence or accidents; or (c) have been used in a manner contrary to Seller's instructions or recommendations. Seller shall not be responsible for design errors due to inaccurate or incomplete information supplied by Buyer or its representatives.
 - 4. U.S. EXPORT CONTROLS:** If applicable, Seller shall file for a U.S. export license only after appropriate documentation for the license application has been provided by Buyer. Buyer shall furnish such documentation within a reasonable time after order acceptance. Any delay in obtaining such license shall suspend delivery dates of EQUIPMENT without liability to either party. If export license is not granted or is revoked by the appropriate authorities, the ORDER may be cancelled by Seller in accordance with the Seller's cancellation policy. Seller will ship the ORDER in accordance with the United States Department of Commerce's Export Administration Regulations. Export or re-export of the ORDER contrary to U.S. law is prohibited.
 - 5. SELLER'S LIABILITY:** Seller will not be liable for any loss, damage, cost of repairs, incidental or consequential damages of any kind, whether based upon warranty (except for the obligation accepted by Seller under "Warranty" above), contract or negligence, arising in connection with the design, manufacture, sale, use or repair of the products or of the engineering designs supplies to Buyer.
 - 6. RETURNS:** Seller cannot accept return of any products unless its written permission has been first obtained, in which case same will be credited subject to the following: (a) All material returned must, on its arrival at Seller's plant, be found to be in first-class condition; if not, cost of putting in saleable condition will be deducted from credit memoranda; (b) A handling charge will be made from all credit memoranda issued for material returned; (c) Transportation charges, if not prepaid, will be deducted from credit-memoranda.
 - 7. SHIPMENTS:** All products sent out will be carefully examined, counted and packed. The cost of any special packing or special handling caused by Buyer's requirements of requests shall be added to the amount of the order. No claim for shortages will be allowed unless made in writing within ten (10) days of receipt of a shipment. Claims for products damaged or lost in transit should be made on the carrier, as Seller's responsibility ceases, and title passes, on delivery to the carrier.
 - 8. SPECIAL PRODUCTS:** Orders covering special or non-standard products are not subject to cancellation except on such terms as Seller may specify on application.
 - 9. PRICES AND DESIGNS:** Prices and designs are subject to change without notice. All prices are F.O.B. Point of Shipment, unless otherwise stated.
 - 10. TAXES:** The amount of any sales, excise or other taxes, if any, applicable to the products covered by this order, shall be added to the purchase price and shall be paid by Buyer unless Buyer provides Seller with an exemption certificate acceptable to the taxing authorities.
 - 11. MINIMUM INVOICE:** \$200.00 plus transportation on complete valve assemblies. \$100.00 plus transportation on replacement parts.
 - 12. TERMS:** Cash, net 30 days unless otherwise specified.
- WARNING**
Engineered Process Solutions Group Valves are designed and manufactured using good workmanship and materials, and they meet all applicable industry standards. These valves are manufactured with various materials, and they should be used only in services recommended by a company engineer. Misapplication of the product may result in injuries or property damage. A selection of valve components of the proper material and consistent with the particular performance requirement is important for proper application.
- Examples of the misapplication or misuse of any Engineered Process Solutions Group products include use in an application in which the pressure / temperature rating is exceeded or failure to maintain valve as recommended and use of products to handle caustic and / or hazardous substances when not designed for that purpose.
- If the valve exhibits any indication or leakage, do not operate. Isolate valve and either repair or replace.
- KRYTOX® is a registered trademark of DuPont
Cam-Line® is a registered trademark of ITT Industries
Cam-Tite® is a registered trademark of ITT Industries
Dia-Flo® is a registered trademark of ITT Industries

ITT Engineered Valves: 65 Years of Providing Quality, Innovative Solutions

ITT Engineered Valves has earned the reputation for delivering the highest quality, innovative valve solutions for a wide range of industrial fluid control needs. These best in-class quality valves have been the foundation for industries such as Mining, Power Generation, Pollution Control, Pulp and Paper, Chemical Processing, Water Treatment, Pharmaceutical, Food and Beverage, and Bio-Processing.

Through both standard and custom designed valve assemblies, ITT Engineered Valves is your partner in providing the best quality and value engineered solutions for your unique flow control needs.

- Dia-Flo® Diaphragm Valves
- Fabri-Valve® Knife Gate, Slide Gate, Wedge Gate and Custom-Fabricated Valves
- Cam-Tite® Hazardous and Critical Duty Ball Valves
- Cam-Line® Plastic Lined Ball Valves
- Skotch® Burner Safety Shut-Off valves



Lancaster, PA Facility



Amory, MS Facility



ITT Engineered Valves
33 Centerville Road
Lancaster, PA 17603, USA
Tel: +1 (717) 509-2200

**Cam-Line, Cam-Tite, Dia-Flo,
EnviZion, Pure-Flo, Skotch**

ITT Engineered Valves
1110 Bankhead Avenue
Amory, MS 38821, USA
Tel: +1 (662) 256-7185

Fabri-Valve

ITT Bornemann GmbH
31683 Obernkirchen
Germany
Tel: +49 5724 390-0

EnviZion, Pure-Flo

