



# Installation, Operation, and Maintenance Manual

Handwheel Operated Valves (970)



**ITT**



---





# Table of Contents

<b>1 Introduction and Safety .....</b>	<b>2</b>
1.1 Safety message levels .....	2
1.2 User health and safety .....	2
<b>2 Transportation and Storage.....</b>	<b>4</b>
2.1 Handling and unpacking guidelines.....	4
2.2 Storage, disposal, and return requirements .....	4
<b>3 Product Description .....</b>	<b>5</b>
3.1 Topworks identification .....	5
3.2 Bonnet description.....	5
3.3 Valve diaphragm identification.....	5
<b>4 Installation.....</b>	<b>7</b>
4.1 Install the valve and topworks .....	7
4.2 Tighten the bonnet fasteners.....	7
4.2.1 Fastener torque table for valve body to topworks .....	8
4.3 Set the travel stop .....	8
<b>5 Operation.....</b>	<b>10</b>
5.1 Topworks operation .....	10
<b>6 Maintenance.....</b>	<b>11</b>
6.1 Precautions .....	11
6.2 Inspection .....	11
6.3 Lubrication requirements.....	11
6.4 Disassemble the valve .....	11
6.5 Replace the valve diaphragm.....	12
6.6 Change the diaphragm type.....	12
6.7 Replace the o-ring .....	12
<b>7 Parts List and Cross-Sectionals .....</b>	<b>14</b>
7.1 970 stainless steel bonnet.....	14

# 1 Introduction and Safety

## 1.1 Safety message levels

### Definitions

Safety message level	Indication
 <b>DANGER:</b>	A hazardous situation which, if not avoided, will result in death or serious injury
 <b>WARNING:</b>	A hazardous situation which, if not avoided, could result in death or serious injury
 <b>CAUTION:</b>	A hazardous situation which, if not avoided, could result in minor or moderate injury
 <b>ELECTRICAL HAZARD:</b>	The possibility of electrical risks if instructions are not followed in a proper manner
<b>NOTICE:</b>	<ul style="list-style-type: none"> <li>• A potential situation which, if not avoided, could result in an undesirable result or state</li> <li>• A practice not related to personal injury</li> </ul>

## 1.2 User health and safety

### General precautions

This product is designed and manufactured using good workmanship and materials, and meets all applicable industry standards. This product should be used only as recommended by ITT.



### **WARNING:**

- Misapplication of the valve can result in injury or property damage. Select valves and valve components of the proper materials and make sure that they are consistent with your specific performance requirements. Incorrect application of this product includes but is not limited to:
  - Exceeding the pressure or temperature rating
  - Failing to maintain this product according to the recommendations
  - Using this product to contain or control media that is incompatible with the materials of construction
  - Proper containment or protection from hazardous media must be provided by the end user to protect employees and the environment from valve discharge.

### Qualifications and training

The personnel responsible for the assembly, operation, inspection, and maintenance of the valve must be appropriately qualified. The operating company must do the following tasks:

- Define the responsibilities and competency of all personnel handling this equipment.
- Provide instruction and training.
- Ensure that the contents of the operating instructions have been fully understood by the personnel.

Instruction and training can be carried out by either ITT or the reseller of the valve by order of the operating company



---

**WARNING:**

California Proposition 65 Cancer <http://www.P65Warnings.ca.gov>. Plastics in product contain Glass Wool Fibers, known to the State of California to cause cancer. Wash hands after handling.

---

**Non-compliance risks**

Failure to comply with all safety precautions can result in the following conditions:

- Death or serious injury due to electrical, mechanical, and chemical influences
- Environmental damage due to the leakage of dangerous materials
- Product damage
- Property damage
- Loss of all claims for damages

**Operational safety precautions**

Be aware of these safety precautions when operating this product:

- Do not remove the contact guard for moving parts when the product is in operation. Never operate the product without the contact guard installed.
- Do not hang items from the product. Any accessories must be firmly or permanently attached.
- Do not use the product as a step or hand hold.
- Do not paint over the identification tag, warnings, notices, or other identification marks associated with the product.

**Maintenance safety precautions**

Be aware of these safety precautions when performing maintenance on this product:

- You must decontaminate the product if it has been exposed to harmful substances such as caustic chemicals.

**Use of unauthorized parts**

Reconstruction or modification of the product is only permissible after consultation with ITT. Genuine spare parts and accessories authorized by ITT serve to maintain safety. Use of non-genuine ITT parts can annul liability of the manufacturer for the consequences. ITT parts are not to be used in conjunction with products not supplied by ITT as this improper use can annul all liability for the consequences.

**Unacceptable modes of operation**

The operational reliability of this product is only guaranteed when it is used as designated. The operating limits given on the identification tag and in the data sheet may not be exceeded under any circumstances. If the identification tag is missing or worn, contact ITT for specific instructions.

Do not use "cheater bars" to operate manual valves. Damage to the valve or personal injury could result.

# 2 Transportation and Storage

## 2.1 Handling and unpacking guidelines

---



**CAUTION:**

Always observe the applicable standards and regulations regarding the prevention of accidents when handling the product.

---

### Handling guidelines

Follow these guidelines when handling the product to prevent damage:

- Use care when handling the product.
- Leave protective caps and covers on the product until installation.

### Unpacking guidelines

Follow these guidelines when unpacking the product:

1. Inspect the package for damaged or missing items upon delivery.
2. Note any damaged or missing items on the receipt and freight bill.
3. Do not lift or pull on the electrical conduit lines. Doing so may cause the POC switches to come out of calibration.

## 2.2 Storage, disposal, and return requirements

### Storage

If you are not immediately installing the product after delivery, store it as follows:

- Store the product in a dry room that maintains a constant temperature.
- Make sure that the products are not stacked on top of one another.

### Disposal

Dispose of this product and associated components in compliance with federal, state, and local regulations.

### Return

Ensure these requirements are met before you return a product to ITT:

- Contact ITT for specific instructions on how to return the product.
- Clean the valve of all hazardous material.
- Complete a Material Safety Data Sheet or Process Data Sheet for any process fluid that could remain on the valve.
- Obtain a Return Material Authorization from the factory.

# 3 Product Description

## 3.1 Topworks identification

### Model number

Code	Description
970	Rising handwheel with travel stop

## 3.2 Bonnet description

### Non-Sealed bonnet

The non-sealed bonnet has a weep hole that indicates a diaphragm failure by allowing process fluid that accumulates in the bonnet to pass through the hole.

## 3.3 Valve diaphragm identification

### Diaphragm tab codes

All diaphragm materials and physical properties are batch traceable via permanent codes molded into the diaphragm tabs. The molding date, grade of diaphragm, and size provide traceability to original batch records.



1. Date code
2. Supplier code

**Figure 1: Elastomer diaphragm front**



- 1. Valve size
- 2. Grade of diaphragm

**Figure 2: Elastomer diaphragm back**



- 1. Material code
- 2. Date code

**Figure 3: PTFE diaphragm**



# 4 Installation

## 4.1 Install the valve and topworks

### NOTICE:

The topworks size and configuration can limit the actual operating pressure. Consult the Pure-Flo catalog for pressure limitations. Consult the factory or engineering catalog for vacuum operation.

1. If you have a weld end valve, then consider the following:

If you are welding ...	Then ...
Manually	Remove the topworks.
In line for schedule 5 or lighter pipe and tubing	You can weld with automatic equipment. Before you perform the weld: <ol style="list-style-type: none"> <li>1. Remove the topworks (optional).</li> <li>2. If left installed, set the valve to the open position.</li> <li>3. Properly purge the valve with an inert gas.</li> </ol>

2. Install the valve.
3. Prior to pressurization (with the valve slightly open), tighten the bonnet fasteners. For more information, see [4.2 Tighten the bonnet fasteners on page 7](#).
4. Cycle the valve two to three times to verify smooth operation.

## 4.2 Tighten the bonnet fasteners



### CAUTION:

Do not tighten fasteners while the system is pressurized or at elevated temperatures (greater than 38°C | 100°F).

1. Depressurize the system.
2. Tighten the bonnet fasteners in a crisscross pattern. For more information, see [4.2.1 Fastener torque table for valve body to topworks on page 8](#).
3. Make multiple crisscross passes to build up torque to the final table value. Make additional crisscross passes using final table values to evenly tighten each fastener to within 5% of torque value.
4. Retighten the bonnet fasteners as noted above at ambient conditions after the system has cycled through operating pressure and temperature.
5. Monitor the valve for leakage:

If leakage ...	Then ...
Occurs at the body/bonnet flange sealing area	Depressurize the system and retighten the bonnet fasteners as noted above.
Continues	Depressurize the system and retighten the bonnet fasteners as noted above. (maximum 3rd re-torque)
Continues	Replace the valve diaphragm.

For more information, see [6.5 Replace the valve diaphragm on page 12](#).

## 4.2.1 Fastener torque table for valve body to topworks

Values given are for lubricated fasteners.

Valve size		PTFE diaphragm		Elastomer diaphragm	
Inch	DN	in-lb	N-m	in-lb	N-m
0.50	15	25–80	2.8–9.1	20–40	2.3–4.5
0.75	20	50–80	5.7–9.1	20–50	2.3–5.7
1.00	25	65–120	7.4–13.6	45–70	5.1–7.9
1.25 and 1.50	32 and 40	200–225	23–25	75–130	8.5–14.7
2.00	50	225–300	25–34	100–180	11–20

## 4.3 Set the travel stop

1. Do you have a test fixture?
  - If Yes: Follow steps 2 through 6.
  - If No: Proceed to step 7.

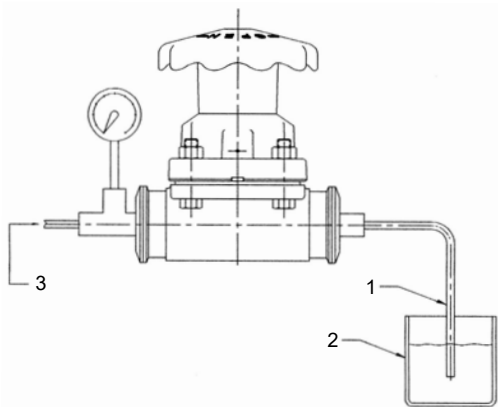

1. Tubing
  2. Beaker of water
  3. Air supply
2. Remove the travel stop screw.
  3. Supply air pressure equal to the system operating pressure to one side of the valve.
  4. Cap the other side of the valve and install a venting rubber or plastic tube.
  5. Hold the tube in a container of water.
  6. Turn the handwheel closed until the leakage stops.  
Air bubbles indicate leakage.
  7. Remove the travel stop screw.
  8. Do you have a weir valve?
    - If Yes: Follow the steps below.
    - If No: You must set the travel stop with a test fixture, following the instructions above.
  9. If you have an elastomer diaphragm, then follow the steps below:
    - a) Remove pressure from the line containing the valve.
    - b) Remove the bonnet fasteners, nuts, and bonnet.
    - c) Unscrew the diaphragm from the compressor.  
Leave the compressor on the spindle.

- d) Replace the bonnet on the valve body without a diaphragm.
  - e) Replace two bonnet fasteners and nuts on opposite sides of the bonnet and hand tighten.
  - f) Turn the handwheel until the compressor touches the weir.  
The valve will not close further.
  - g) Push down on the handwheel until it bottoms on the travel stop surface of the bonnet.
  - h) Install and tighten the travel stop screw.
  - i) Remove the bonnet from the valve body.
  - j) Screw a diaphragm into the compressor and hand tighten. Back off the diaphragm until the bolt holes in the diaphragm and bonnet flange align.
  - k) Rotate the handwheel counterclockwise just enough to permit the flange area of the diaphragm to rest flat against the flange area of the bonnet.
  - l) Replace the bonnet on the valve body.  
The bonnet should be opened one half to one turn of the handwheel.
  - m) Tighten the bonnet fasteners.  
For more information, see Tighten the bonnet fasteners in Installation.
10. have a PTFE diaphragm, then follow the steps below:

# 5 Operation

## 5.1 Topworks operation

The valve is closed with a clockwise rotation of the handwheel.

# 6 Maintenance

## 6.1 Precautions



### WARNING:

- All procedures must be performed by qualified personnel.
- When the process fluid is hazardous, thermal (hot or cold), or corrosive, take extra precautions. Employ the appropriate safety devices and be prepared to control a process media leak.
- Always wear protective clothing and equipment to safeguard the eyes, face, hands, skin, and lungs from the fluid in the line.

## 6.2 Inspection

Inspection area	What to look for	Action if problem is found
External valve parts	Excessive wear or corrosion	<ul style="list-style-type: none"> <li>• Replace the affected parts</li> <li>• Contact ITT to obtain replacement parts or for specific instructions</li> </ul>
Non sealed bonnet		Replace the valve diaphragm
Topworks	Spindle binding, excessive noise, or dried lubricant	
Diaphragm and valve body	Leakage between the diaphragm and valve body	Tighten the bonnet fasteners

For more information, see:

- [6.5 Replace the valve diaphragm on page 12](#)
- [4.2 Tighten the bonnet fasteners on page 7](#)

## 6.3 Lubrication requirements

### Lubrication schedule

Remove residual grease prior to re-lubrication. Lubricate the spindle threads, lower spindle face and neck where it interfaces with the compressor, and o-ring whenever the topworks is disassembled. Bonnets are not equipped with grease fittings and must be disassembled to be lubricated.

### Acceptable lubricants

Brand	Lubricant type
Chevron	DOW 111 for o-ring

## 6.4 Disassemble the valve

1. Remove all line pressure.
2. Remove the bonnet fasteners.
3. Lift the topworks assembly from the valve body.
  - a) Lift off the bonnet.

- b) Rotate the handwheel to lower the compressor diaphragm assembly.

## 6.5 Replace the valve diaphragm

1. Disassemble the valve.  
For more information, see [6.4 Disassemble the valve on page 11](#).
2. Unscrew the diaphragm from the compressor by turning the diaphragm counterclockwise.  
The replacement diaphragm should be identical in size and grade to the original diaphragm.
3. Rotate the diaphragm until hard stop or heavy resistance is achieved and additional force does not significantly rotate the diaphragm into the compressor.



4. If replacing a PTFE diaphragm, re-invert the diaphragm.



5. For more information, see [4.2 Tighten the bonnet fasteners on page 7](#).

## 6.6 Change the diaphragm type

1. Remove the bonnet nuts and lift off the bonnet.
2. Remove the travel stop screw.
3. Turn the handwheel clockwise to lower the compressor and slide the compressor off the spindle.
4. Change to the new compressor.

If you are changing ...	Then ...
From an elastomer to a PTFE diaphragm	Install a tube nut into the hexagonal hole in the new compressor
From a PTFE to an elastomer diaphragm	Change to the new compressor.

5. Lubricate the spindle end where it interfaces with the compressor.
6. Locate the new compressor on the spindle and turn the handwheel counter clockwise to raise the assembly into the bonnet.
7. Replace the diaphragm.  
For more information, see [6.5 Replace the valve diaphragm on page 12](#).

## 6.7 Replace the o-ring

1. Remove the travel stop screw and handwheel.

2. Remove the o-ring from the groove in the bonnet.
3. Clean the o-ring groove.
4. Apply lubricant to the o-ring.
5. Install the o-ring into the groove.
6. Reinstall the handwheel.
7. Set the travel stop.  
For more information, see [4.3 Set the travel stop on page 8](#).

# 7 Parts List and Cross-Sectionals

## 7.1 970 stainless steel bonnet

### List of parts

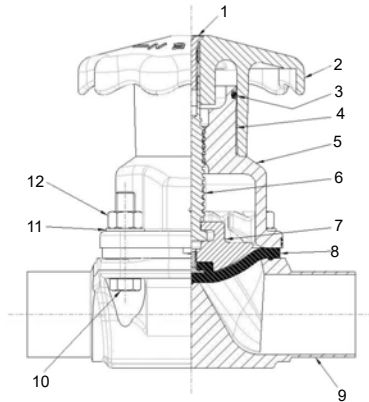

Figure 4:

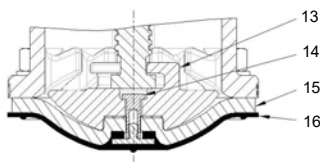

Figure 5: Plastic diaphragm and compressor

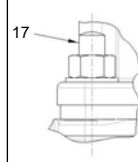

Figure 6: Bolt detail for tank bottom body, block body and fabrications

Item	Description	Material	Quantity
1	Travel stop screw	Stainless steel	1
2	Handwheel	PAS	1
3	O-ring	FKM (FDA)	1
4	Label indicating	Mylar	1
5	Bonnet	Stainless steel	1
6	Spindle	Stainless steel	1
7	Compressor for elastomer	Bronze or stainless steel	1
8	Elastomer diaphragm	EPDM, Buna N	1
9	Body	Stainless steel	1
10	Cap screw	Stainless steel	4
11	Washer	Stainless steel	4
12	Nut	Stainless steel	4
13	Compressor for plastic	Bronze or stainless steel	1
14	Tube nut	Brass	1
15	Backing cushion	EPDM	1
16	Plastic diaphragm	PTFE, Grade TM	1
17	Stud	Stainless steel*1	As required

\*1 ASME grade fasteners available on tank bottom valve



**Visit our website for the latest version of  
this document and more information:**  
[www.engvalves.com](http://www.engvalves.com)



ITT Engineered Valves  
33 Centerville Raod  
Lancaster, PA 17603  
USA

**Form IOM-RHWO.en-US.2022-11**

©2022 ITT Inc. or its wholly-owned subsidiaries  
The original instruction is in English. All non-English instructions are translations of the original instruction.